

SERVICE**BULLETIN**

SB #: F110
DATE: APRIL 2012
TO: ALL AUTHORIZED FERRIS DEALERS
SUBJECT: UPDATES TO IS5100Z HYDRAULIC LIFT SYSTEM
MODELS: SEE LIST BELOW

BRANDS:

Brand	Model Numbers	Serial Number Range	Description
Ferris	5900507, 5900979, 5900995, 5900996, 5901011 & 5901013	2015381236 & Below	IS5100Z Series Zero-Turn Riding Mower

DESCRIPTION

This bulletin is for IS5100Z series zero-turn riding mowers equipped with hydraulic deck lift systems and details the inspection and correction procedures for updating the system for better performance.

INSPECTION PROCEDURES

1. Observe the mower and see if it is equipped with a deck lift spring (**A, Figure 1**) on the left hand side of the mower.
2. If your mower **does** have the deck lift spring installed, your unit is not affected and no changes are necessary.

If your mower **does not** have the deck lift spring installed, continue with *Corrective Procedures*.

CORRECTIVE PROCEDURES

1. Order and install the Hydraulic Valve Update Kit (Part # 5600583).

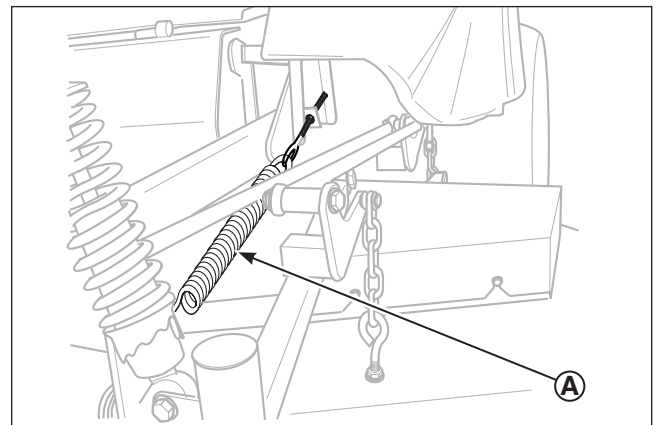

Figure 1. Inspecting the Unit
A. Deck Lift Spring

WARRANTY:

File for warranty reimbursement using e-Claim at www.ThePowerPortal.com. Use the values listed below when filling out the claim. The information in the "Brand" block indicates which tab the claim should be filed under. *Note: File only one unit per claim form.*

Brand	Ferris	Cause of Failure	F110
Failure Location Category	L&G - Deck/Attachment	Work Performed	F110
Failure Location Code	F92	Repair Parts Used	5600583 (Qty: 1)
Defect Code/Failure Mode	AW		
Control/Evaluation Number	F110		
Pick-Up & Delivery	N/A		
Total Hours (Tenths):			

BRIGGS & STRATTON POWER PRODUCTS GROUP, LLC
 Distribution Sales & Customer Support